

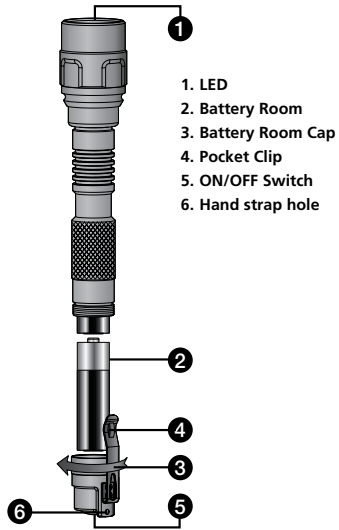

FLASH-150Z Industrial LED Flashlight with Zoom



1. LED
2. Battery Room
3. Battery Room Cap
4. Pocket Clip
5. ON/OFF Switch
6. Hand strap hole

SYMBOLS

	Caution ! Refer to the explanation in this Manual
	Do not dispose of this product as unsorted municipal waste. Contact a qualified recycler for disposal.

⚠ WARNING and PRECAUTIONS

- Do not look at the LED light directly
- Do not allow children to use the LED light alone
- Flashlight surface maybe hot after using

UNPACKING AND INSPECTION

Your shipping carton should include:

- 1 Flashlight
- 2 AA batteries
- 1 Hand strap
- 1 Users Manual

If any of the items are damaged or missing, return the complete package to the place of purchase for an exchange.

INTRODUCTION

The flashlight FLASH-150Z is a portable electric spotlight, the whole body is made of metal; it can be used in most of worst condition.

Features

- Osram Golden Dragon Plus LED
- Maximum light output: Up to 130 lumens
- Continuous run time: Up to 1.6 hours
- Powered by two AA alkaline batteries
- Compatible to AA Ni-MH rechargeable batteries
- Precise design, optical pre-focused collimator lens
- Push-button tail cap switch
- Momentary ON/OFF function
- Steel pocket clip
- Product size: 165(H) x 30(W)mm (6.5(H) x 1.2(W) inch)

OPERATION

1. Unscrew the end cap and install AA batteries into battery room
2. Screw on the end cap
3. Push ON/OFF button; and turn on flashlight

Limited Warranty and Limitation of Liability

Your Amprobe product will be free from defects in material and workmanship for 1 year from the date of purchase. This warranty does not cover disposable batteries or damage from accident, neglect, misuse, alteration, contamination, or abnormal conditions of operation or handling. Amprobe's warranty obligation is limited, at Amprobe's option, to refund of the purchase price, free of charge repair, or replacement of a defective product. To obtain service during the warranty period, return the product with proof of purchase to an authorized Amprobe Test Tools Service Center or to an Amprobe dealer or distributor. This warranty is your only remedy. All other warranties - whether express, implied or statutory - including implied warranties of fitness for a particular purpose or merchantability, are hereby excluded. Neither Amprobe nor its parent company or affiliates shall be liable for any special, indirect, incidental or consequential damages or losses, arising from any cause or theory. Since some states or countries do not allow the exclusion or limitation of an implied warranty or of incidental or consequential damages, this limitation of liability may not apply to you.

Repair

All test tools returned for warranty or non-warranty repair or for calibration should be accompanied by the following: your name, company's name, address, telephone number, and proof of purchase. Additionally, please include a brief description of the problem or the service requested and include the test leads with the meter. Non-warranty repair or replacement charges should be remitted in the form of a check, a money order, credit card with expiration date, or a purchase order made payable to Amprobe® Test Tools.

In-Warranty Repairs and Replacement – All Countries

Please read the warranty statement and check your battery before requesting repair. During the warranty period any defective test tool can be returned to your Amprobe® Test Tools distributor for an exchange for the same or like product. Please check the "Where to Buy" section on www.amprobe.com for a list

of distributors near you. Additionally, in the United States and Canada In-Warranty repair and replacement units can also be sent to a Amprobe® Test Tools Service Center (see address below).

Non-Warranty Repairs and Replacement – US and Canada

Non-warranty repairs in the United States and Canada should be sent to a Amprobe® Test Tools Service Center. Call Amprobe® Test Tools or inquire at your point of purchase for current repair and replacement rates.

In USA
Amprobe Test Tools
Everett, WA 98203
Tel: 877-AMPROBE (267-7623)

In Canada
Amprobe Test Tools
Mississauga, ON L4Z 1X9
Tel: 905-890-7600

Non-Warranty Repairs and Replacement – Europe

European non-warranty units can be replaced by your Amprobe® Test Tools distributor for a nominal charge. Please check the "Where to Buy" section on www.amprobe.com for a list of distributors near you.

European Correspondence Address*

Amprobe® Test Tools Europe
In den Engematten 14
79286 Glottertal, Germany
Tel.: +49 (0) 7684 8009 - 0

*(Correspondence only – no repair or replacement available from this address. European customers please contact your distributor.)